

PRODUCT SPECIFICATION

DEKO 192 X2

Ward Washer Disinfector



Preventing infections since 1976.

DEKO
MEDTECH

Intended use

The DEKO 192 X2 Washer Disinfector empties, cleans and thermally disinfects by steam a variety of reusable ward utensils, such as;



Portable sanitary pans



Urine bottles and kidney dishes

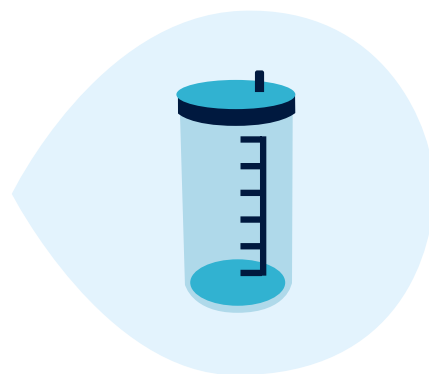

Suction bottles, measuring jugs and various hollowware

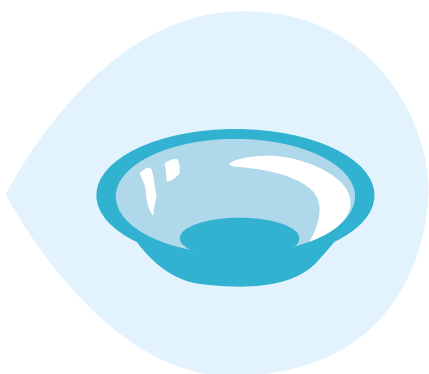

Hospital bowls (patient wash bowls)



Raised toilet seats and toilet brushes / holders

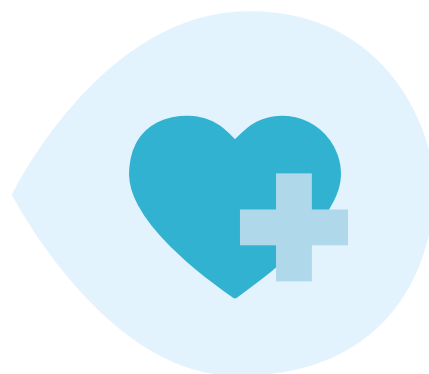

Products alike the above and used for similar purposes within patient care

Main Features

Next-level enhanced hygiene, aseptics and working ergonomics with DEKO 192 X2 pass through Ward Washer Disinfector.



DEKO 192 X2 loading side

Display

Easy-to-use touch screen display providing enhanced process control. DEKO 192 X2 is equipped with 7" colour display.

Increased disinfection

Loading the pass through washer disinfector in a patient room or a sluice room and unloading it in a clean storage room reduces the risk of cross-contamination significantly.

Large capacity

Large wash chamber and capacity for automatic emptying and processing of 2 bedpans with lids and 4 urine bottles simultaneously.

'Non-Touch' door

Automatic door activated by an optical sensor is available as an optional feature.



DEKO 192 X2 unloading side



Features and functionalities

– benefits for the user

Unique washing efficacy

Fresh-water recirculation principle similar to instrument washer-disinfectors provides superior cleaning and disinfection results. Thanks to high water pressure combined with minimum usage of water and energy, an outstanding mechanical washing efficiency is reached on economic consumption values.

Thermal disinfection is executed according to EN ISO 15883 AO=600 requirement and carried out by steam, integrally generated in an unpressurized steam generator. All internal surfaces are washed and in addition to the utensils being processed, the water tank, piping, outlet and chamber are disinfected in each cycle.

Large Capacity, extended versatility

Large wash chamber and capacity for automatic emptying and processing of 2 bedpans with lids and 4 urine bottles simultaneously. The machine is equipped with an integrated drop-down shelf and it can also accommodate specialized inserts and washing accessories to process a large variety of utensils used at wards. See brochure for further information on available washing accessories.

Pass Through

Next-level enhanced hygiene, aseptics and working ergonomics with DEKO 192 X2 pass through Ward Washer Disinfectors. Loading the pass through washer disinfectors in a ward room/washing room and unloading it in a clean storage room reduces the risk of cross-contamination significantly.

Doors

Manual hinged door as standard feature. A 'Non-Touch' door activated by an optical sensor is available as an option for DEKO 192 X2. Door functionality is equipped with secured door interlocking system. A clear text on the display and led light indicator will advise when the door is unlocked for opening.

Loading side door opens 120° making it easy to accommodate the utensils to be washed on correct positions inside the chamber i.e. the machine is designed to empty the utensils on behalf of the user. Unloading side door angle is set to 90°.

Advanced State-of-the-art control

Control by a Programmable Logic Controller (PLC) with the most advanced operating system available today. The access code system protects any unauthorized changes to the washing cycles and set parameters with special codes for maintenance and user defined cycle programming. Special service and maintenance control system restore valuable information for technical performance follow-up and evaluation and enables component testing.

Boss entry port for test temperature sensor leads

Machine is equipped with boss entry port to insert temperature sensors to perform IQ, OQ, PQ (when requested by the user).

Pressure control for foam and washing water

To secure powerful washing efficacy, foam and washing water pressure control ensure proper water pressure is maintained during water circulation and throughout the whole washing cycle. In case of excess foam or sudden drop of circulating water pressure, machine automatically drains the chamber and restarts the aborted process cycle step from the beginning (max. 3 times). Failure to reach the predefined parameters will result in an interruption of the cycle and an error notification on the display.

Independent tamper-proof process recorder

Machine is equipped with a temperature recorder, with sensors and signal processing independent from the controller, to record the attainment of programmed disinfection conditions.

Machine stores all cycle process data such as:

- name of institution
- date & time
- machine identification
- sequential cycle number
- cycle name and configuration
- cycle start and end time
- temperature
- water pressure

Internal storage of 32 GB for recording all process data, transferable to external USB memory stick or throughout an optional network connectivity (FTP over Ethernet) to external fileservers.

USB -memory stick to store the process data

The verification is executed according to EN ISO 15883-1, clause 5.11.4 level b)

Panel printer (optional feature)

Panel printer to print process data (see "Independent temper-proof process recorder").

Network connectivity (Ethernet) (optional feature)

Network connectivity feature allows:

- Remote monitoring of the machine over network
- Logging process events over network to email client
- Sending process data printouts to local and network printer
- Storing process data to external files server (FTP over Ethernet)

See "DEKO WD networking, System description" for more information.

Remote access (optional feature)

Capability for remote access allowing remote service support. See "Deko WD networking, System description" for more information.

Display

Easy-to-use touch screen display providing enhanced process control. DEKO 192 X2 is equipped with 7" colour display. The display provides clear and informative user and service instructions. Cycle phase indication: current cycle name, sequential cycle number, estimated remaining cycle time, current phase and chamber temperature. Additionally, on DEKO 192 X2 pressure indication shown as a graph.

Washing cycles

By default, a choice of 4 different factory-set programs tested and approved to meet standard EN ISO 15883 requirements. Programs are easily adaptable to suit special washing and disinfection requirements. Internal memory provides a pre-set cycle library for creating a practically unlimited number of programs. Machine is also equipped with a user adjustable audible indicator notifying end of cycle.

Detergent dosing

- Suction tube:
The length of the suction tube is adjustable to ensure fit for all types of detergent containers.
- Adjustable detergent pump:
Detergent is dosed onto re-circulating wash water by a pump. Dosage is freely adjustable to match detergent (manufacturer) concentration guidance.
- Detergent low-level indication:
The detergent suction hose is equipped with a float switch to monitor sufficient detergent availability and to advise the user to replace the container when detergent level is below minimum.
- Descale dosage pump (optional feature)
Pump doses requested amount of descale agent into the steam generator on each cycle to prevent formulation of lime thereby prolonging the lifecycle of the heating elements.
- Chamber cleaning
Special factory built-in washing cycle to remove lime deposit from washing chamber using lime removal agent. Note! Lime removal is performed for the chamber only, not for the steam generator as with the descale dosage pump option.
- Flow meter for detergent dosing (optional feature)
Measures the volume of dosed detergent and verifies the correct dosing requested.
- Detergent dosing flushing cycle
Special flushing cycle to remove detergent build-up (precipitate) by hot water from the dosing system.
- Vapour condenser
For evaporating steam generated in thermal disinfection phase after disinfection is finished, allowing chamber door opening immediately after the cycle is completed.
- Back syphon protection
Machines is equipped with either backflow prevention valve or open air gap solution to prevent back syphon from water supply. Please consult local authorities to check country specific requirements.

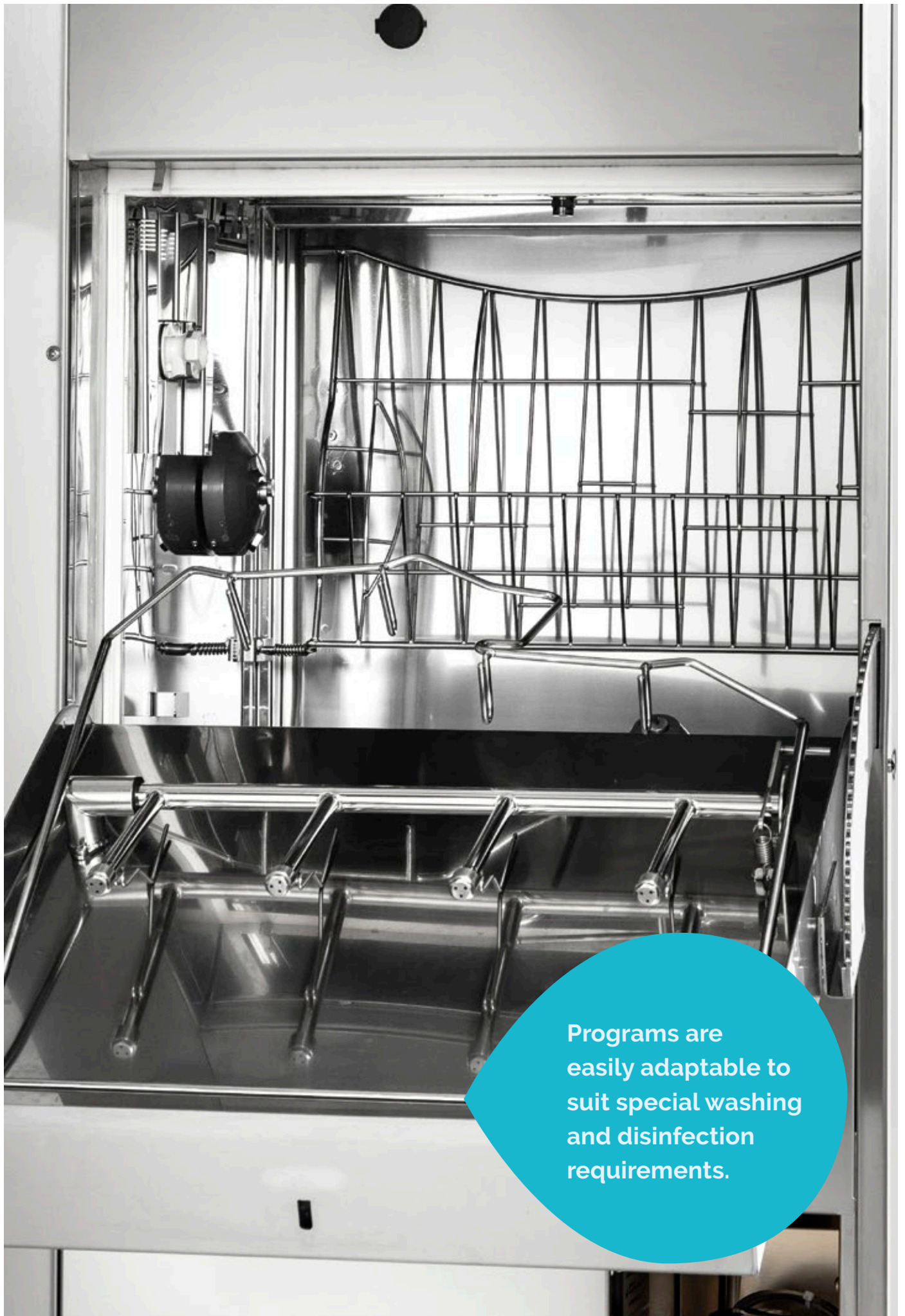

Programs are easily adaptable to suit special washing and disinfection requirements.

Technical info

Model	DEKO 192 X2
Material	Stainless EN 1.4301 steel
User interface / Display	
7" colour Touch-Screen	X
Door functioning	
Opening	Automatic Non-Touch / Manual
Opening angle, loading side	120°
Opening angle, unloading side	90°
Washing mechanics	
3 rotating + 7 fixed wash jets	X
Water recirculation pump, power kW / output l / min	1.6 / 600
Measurements	
Width (mm)	700
Depth (mm)	666
Height (mm)	1540
Height, raised legs model	1690 / 1720*
Usable chamber volume, l	58
Wash chamber dimensions, mm (gross)	W 480 x D 360 x H 640
Loading height, mm	835
Loading height, raised legs model	985 / 1015 *
Weight, kg	130
Floor loading, kN/cm ²	0.04
Adjustable feet for levelling ±10 mm	X
Utility connections and consumption	
Back syphon protection *	Backflow prevention valve / Open air gap
Cold water (max 15 °C) inlet hose, G1/2" female thread, length 2 m	X
Warm water (max 65 °C) inlet hose, G1/2" female thread, length 2 m	X
Min – max water pressure, bar	1–8
Water volume per cycle phase, l	
• cold water flush	9
• mixed (cold and warm 50/50) water flush	9
• wash with detergent	9
• warm water rinse	9
• thermal disinfection (water quantity to generate steam)	2
• total	38
Floor drain outlet ø 110 mm	X
Vapour condenser	X
Required property ventilation (exhaust air) capacity, l/s	30
Other technical features	
Total maximum heat transmission (W/m ²)	100
Maximum fascia heat transmission (W)	60
Mean sound power level (A), dB	65
Heating power (kW) *	6,6 / 7,5
Automatic detergent dosing system	
Suction tube *	Adjustable / Telescopic
Integrated detergent container housing	X
Detergent container housing lockable door	O
Adjustable detergent pump	X
Detergent low level indication	X
Descale dosage pump	O
Detergent flow verification	O

Model	DEKO 192 X2
Process control	
Load temperature protection and over temperature cut-outs	X
Pressure control for foam and washing water	X
Cycle complete indication with mutable buzzer	X
Boss entry port for test temperature sensor leads	X
Independent tamper-proof process verification	X
Independent tamper-proof process recorder	X
Panel printer	O
Network connectivity (Ethernet)	O
Remote access	O
Emergency stop switch	O
Standard compliance	
EN ISO 15883	EN ISO 15883-1, -3
IEC 61010-1	X
IEC 61010-2-040	X
IEC 61326-1	X
CE 0537	X

X = Standard O = Optional – = Not available / not applicable * = Regional options

Electric connection*

Plate values	Voltage	Current	Power	Frequency	Phases	Connection	Fuse
U 400 V 3N AC 50/60 Hz, 11 A	400 V	10,9	7500W/400V	50/60 Hz	3 N	star	3x16A
U 400 V 3N AC 50/60 Hz, 2,5 A	400 V	2,3	1600 W Steam heated	50/60 Hz	3 N	star	3x10A
U 400 V 3N AC 50/60 Hz, 9,8 A	400 V	9,6	6600W/400V	50/60 Hz	3 N	star	3x10A
U 230 V 1N AC 50 Hz, 29 A	230 V	28,7	6600W/230V	50 Hz	1 N	star	1x32A

Installation of the DEKO192 X2 washers

1. See available voltage rating variants on the table
2. Cold water, flexible inlet hose with G½" female thread, L = 2
3. Warm water, flexible inlet hose with G½" female thread, L = 2 m
4. Waste outlet floor installation Ø110 mm (dimensions for center of the outlet)

Dimensions

Wall opening width 890 mm, depth max 350 mm, height 1600 mm*.

NB! Dimensions apply to standard height machine. If the machine is equipped with raised legs, 150/180 mm* should be added to dimensions marked with an asterisk (*).

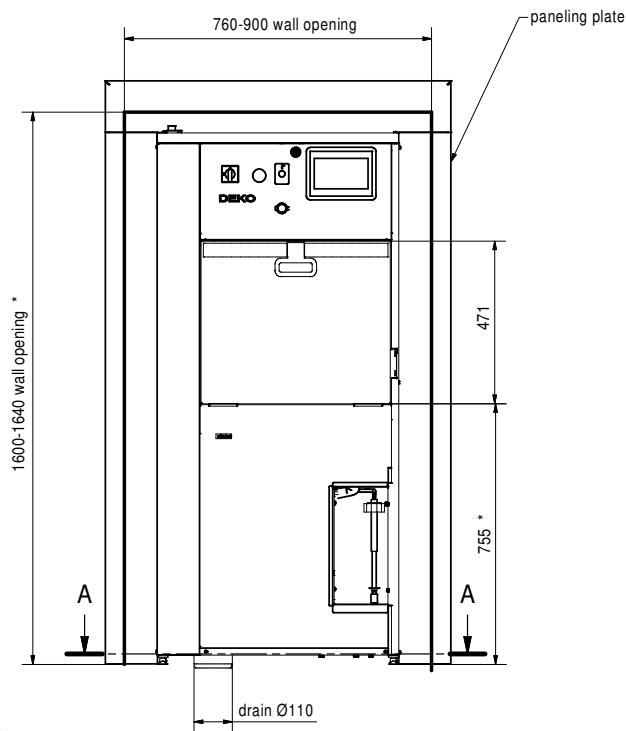

A-A (1 : 10)

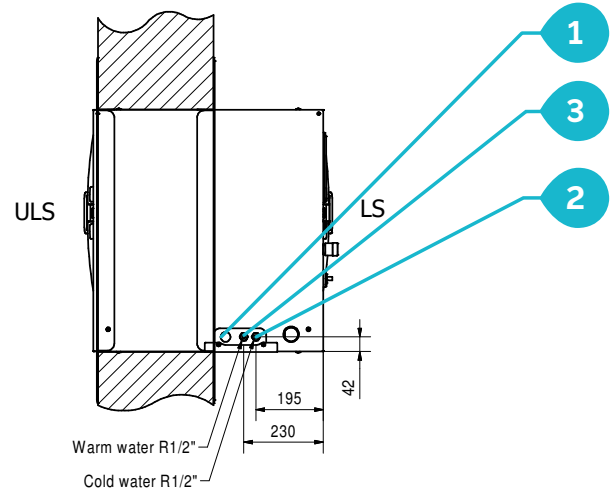
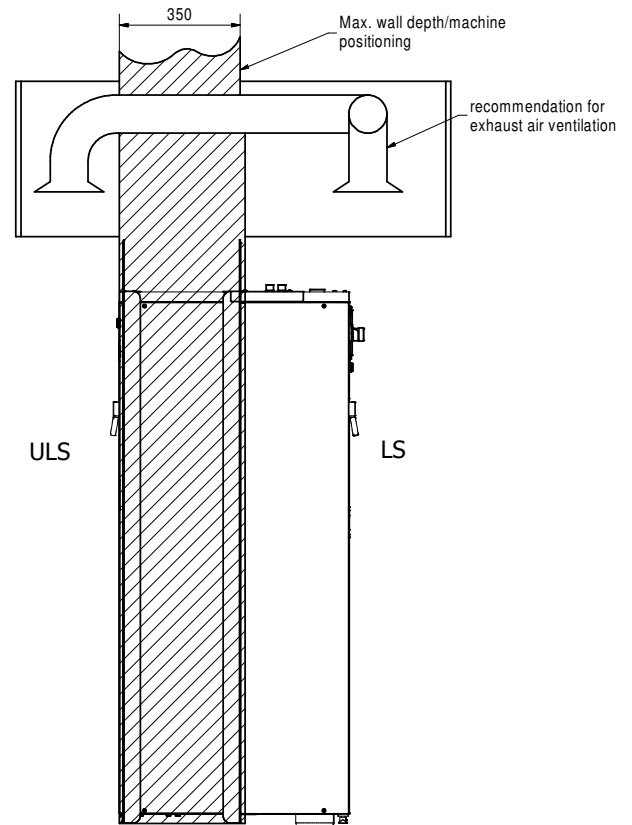
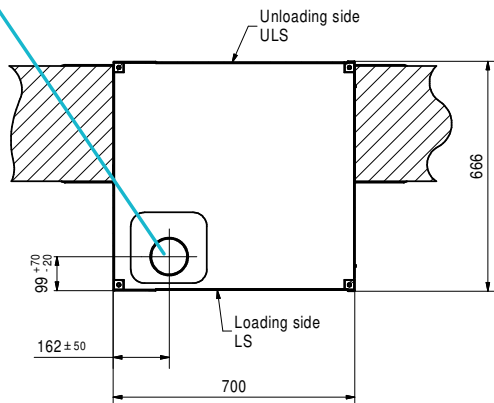

Installation to the drain

The drain connection of the installation site must be prepared accordingly.

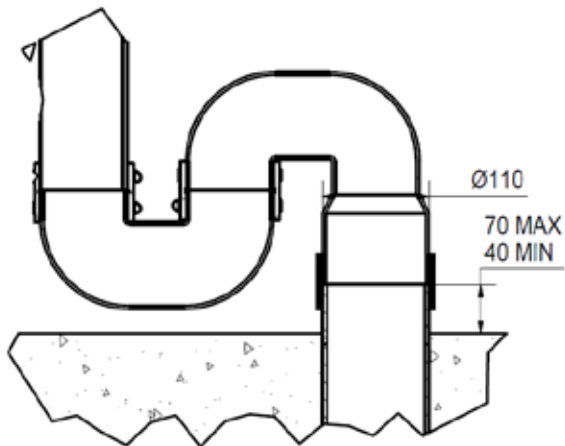

Installation to a drain without muff:

The height of the floor drain must be between 40..70mm.

Cut the plastic drain of the machine to fit the floor drain height.

Connect the drain with collar connector. It is recommended to use a good quality double-bolt collar. (Collar connector is not included with the machine).

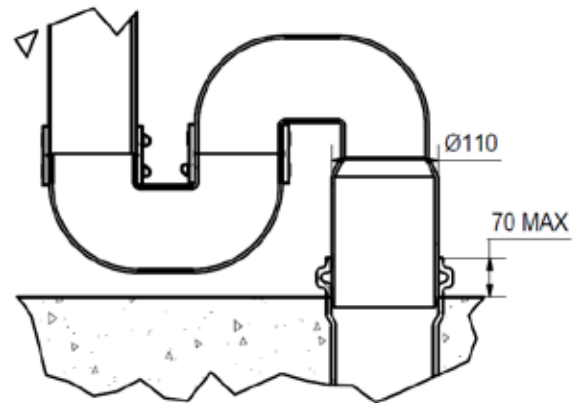

Installation to a drain with a muff:

Recommended height of the muff max. 70mm.

Cut the drain to appropriate length so it does not reach the bottom of the muff.

After cutting, carefully remove any sharp burrs from the cutting surface. This will prevent damage to the rubber seal.



Preventing infections since 1976.

DEKO MedTech Oy | Vartiokuja 1 | FI-76850 Naarajärvi | Finland
www.dekomedtech.com

REV: 08/04/2024